

## GMP-6/GMP-18

Residential/Small Commercial Hydronic System Feeders by the leader in Commercial Glycol Make-Up Packages.

The HG Spec GMP-6 and GMP-18 are economical yet rugged, compact and easy to use fluid feeders for smaller closed-loop systems. Their function is to automatically supply pressurized water or a water/glycol mixture to a closed-loop space heating, chilled water, snowmelt, radiant heating or process control system, to insure that minimum system pressure levels are maintained. The optional remote alarm panel kit will provide an audible and visual indication of a system leak.

### Advantages of using automatic system feeders:

#### PREVENTS MAJOR FLOODS

In the event of a major system leak, only the contents of the storage tank will be pumped into the system.

#### NO DIRECT CONNECTION TO POTABLE WATER SUPPLY

Eliminates the need for backflow prevention devices.

#### PROVIDES LEAK DETECTION

Dropping solution level in the storage tank warns of developing system leak.

#### TREATMENT CHEMICALS

Allows mixing of treatment chemicals in make-up water, if desired.

#### AUDIBLE AND VISUAL ALARM

The optional remote alarm kit alerts the user if there is a system leak, allowing quick corrective actions.

### Features:

- Two sizes: GMP-6, 22.7 L (6.0 USG) and GMP-18, 68.1 L (18 USG)
- 120 Vac/1 ph/60 Hz, standard plug with 1.8 m (6 ft) cord
- Level float switch with piggyback plug
- Rugged self-priming diaphragm pump which can run dry
- Level switch stops the pump if fluid level in the tank is too low
- Easy to adjust PRV to maintain system pressure (up to 412.8 kPa (60 psig))

### Options

- Remote alarm panel kit: low level switch and remote panel with 9 V battery backup
- Float and auxiliary dry contact (NO) for remote low level alarm (alarm panel by others)
- Wall mounting shelf for GMP-6: WMS



# HG Spec GMP-6/GMP-18



PL3-03E  
08.01

## Technical information

### CAPACITIES:

GMP-6: 22.7 L (6.0 USG)  
GMP-18: 68.1 L (18 USG)

### ELECTRICAL:

120 Vac/1 ph/60 Hz plug, 1.0 amp

### PUMP:

1.0 L/s (1.6 gpm) at free flow

### DISCHARGE CONNECTION:

3/8" FPT

### WEIGHTS:

GMP-6: Empty 7.4 kg (16 lbs) / Full: 30 kg (66 lbs)  
GMP-18: Empty 11.4 kg (25 lbs) / Full: 79.5 kg (175 lbs)

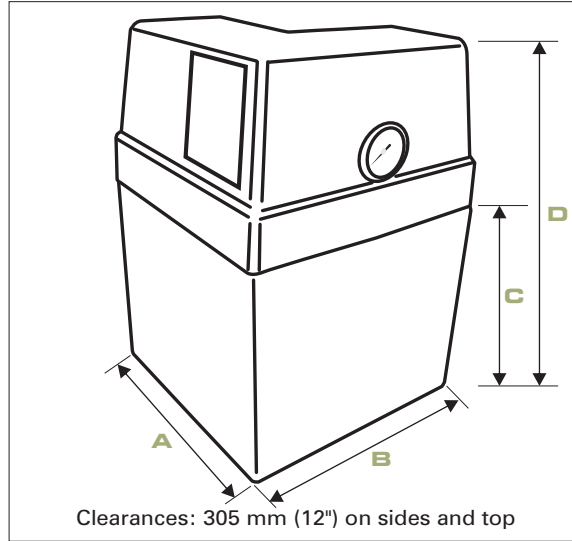

## Models & Dimensions

Pressure: 0 - 172 kPa (0 - 25 psig)

<b>GMP-6</b>	
<b>GMP-6A</b>	With remote alarm panel kit
<b>GMP-18</b>	
<b>GMP-18A</b>	With remote alarm panel kit

All Models	A mm (in)	B mm (in)	C mm (in)	D mm (in)
<b>GMP-6</b>	305 (12)	305 (12)	254 (10)	445 (17.5)
<b>GMP-18</b>	305 (12)	305 (12)	807 (31.75)	997 (39.25)

Pressure: 0 - 412.8 kPa (0 - 60 psig)

<b>GMP-6H</b>	
<b>GMP-6HA</b>	With remote alarm panel kit
<b>GMP-18H</b>	
<b>GMP-18HA</b>	With remote alarm panel kit

### Consult factory for higher pressure systems

### TYPICAL SPECIFICATION

The automatic hydronic system feeder shall be an HG Spec model GMP\_\_\_. The system shall be compatible with solutions containing up to 50% glycol. The system shall be factory assembled and complete with: a storage tank with a 127 mm (5 in) opening with cover, liquid level gauge, pump suction hose with strainer, pressure pump with check valve, cutout piggyback level float switch, adjustable PRV for setting of system pressure from 0 to \_\_\_ kPa (0 to \_\_\_ psig) and pressure gauge. The unit shall be warranted for one (1) year.

### FOR SYSTEMS WITH REMOTE ALARM PANEL KIT (GMP-\_\_\_A)

Remote alarm panel kit: The kit shall include a low level float switch and an alarm panel. The float shall be factory installed and include a 3 m (10') cable for connection to the remote panel. The alarm panel shall include: NEMA 1 indoor enclosure, 1.8 m (6') power cord with 120 V plug, 12 VAC control circuit with 9 Volt battery back-up (battery not included), power and alarm indicator lights, silence and test buttons. The panel shall include auxiliary alarm contacts (1-NO, 1-NC).



### Options:

- Float switch and auxiliary dry contact (NO) for remote low level alarm (Alarm panel by others). (Add suffix R to model number without remote alarm panel kit. Example: GMP-6R).
- Wall mounting shelf for GMP-6: WMS.

**Project:** \_\_\_\_\_ **Location:** \_\_\_\_\_

**Engineer:** \_\_\_\_\_ **Unit tag:** \_\_\_\_\_

**Contractor:** \_\_\_\_\_ **Submitted by:** \_\_\_\_\_

**Represented by:**