

# Bromine Feeders

## Purpose

Neptune Bromine/By-Pass Feeders are a convenient and efficient way to properly feed solid biocides or other corrosive water treatment chemicals.

These units easily handle ball, stick, tablet and other forms of bromine.

Vinylester resin body tanks are superior to standard steel by-pass feeders for shot feeding corrosive chemicals.

## Features

- Feed rates from 2-1/2 through 230 lb. per day.<sup>1</sup>
- Bottom inlet and drain connection.
- Top opening with threaded, gasketted closure.
- Rated to 150 psi at 150°F.
- Optional PVC piping kits include strainers and all required fittings.
- Optional flow indicators in four ranges.
- Pressure relief valves and solenoid valves optional.

**Neptune**  
CHEMICAL PUMP CO., INC.

**MODEL BT-80 TANK**  
with piping, flow indicator and optional relief valve installed



**BROMINE FEEDER INSTALLATION** ▼

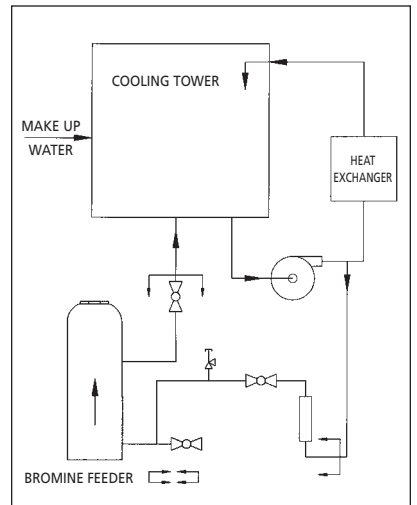

### CALCULATED DELIVERY RATES

MODEL	TOTAL CAPACITY (LBS.)	FLOW RANGE (GPM)	LOWER OUTLET		UPPER OUTLET	
			FEED RATE <sup>1</sup> (LBS./DAY)	RESERVE CAPACITY <sup>2</sup> (LBS.)	FEED RATE <sup>1</sup> (LBS./DAY)	RESERVE CAPACITY <sup>2</sup> (LBS.)
BT-15	15	1 - 10	N/A	N/A	5 - 10	7
BT-40	40	1 - 10	N/A	N/A	6 - 12	27
BT-42	42	1 - 10	N/A	N/A	7 - 11	25
BT-80	80	1 - 10 5 - 21	N/A	N/A	26 - 36 30 - 49	34
BT-160	160	1 - 10 5 - 21	36 - 47 41 - 60	93	71 - 94 82 - 120	26
BT-420	310	20 - 120	N/A	N/A	75 - 230	N/A

<sup>1</sup>These rates based on Dantobrom® manufactured by Lonza Inc. and water at 70°F (21°C).

<sup>2</sup>This represents amount of product above the outlet fitting.

Feed rates will be reduced when using less soluble compounds. Feed rates will vary with water temperature.

# Specifications

## TANKS

Vinylester resin bodies have two threaded side connections, one threaded bottom connection and one 2-1/2" or 4" top opening with threaded gasketed closure. Tanks rated to 150 psi at 150°F. (Note: Model BT-420, 120°F max.)

MODEL	CAPACITY			DIMENSIONS (IN.)				CLOSURE (IN.)	INLET CONN.	OUTLET CONN.
	LBS.	CU. FT.	GAL.	A	B	C	D			
BT-15	15	0.3	2.3	23-1/2	6	15-1/2	N/A	2-1/2	3/4" NPT	3/4" NPT
BT-40	40	0.6	4.8	35-9/16	7	15-1/2	N/A	2-1/2	3/4" NPT	3/4" NPT
BT-42	42	0.7	5.1	24-13/16	10	15	N/A	4	3/4" NPT	3/4" NPT
BT-80	80	1.4	10.4	40-3/4	10	26	N/A	4	1" NPT	1" NPT
BT-160	160	3.1	23.4	53-13/16	12	46-1/4	20	4	1" NPT	1" NPT
BT-420	310	6.1	45.3	48-1/2	22	N/A	N/A	4*	4**	CLOSURE*

\*4": Closure with 1" conn. for piping.

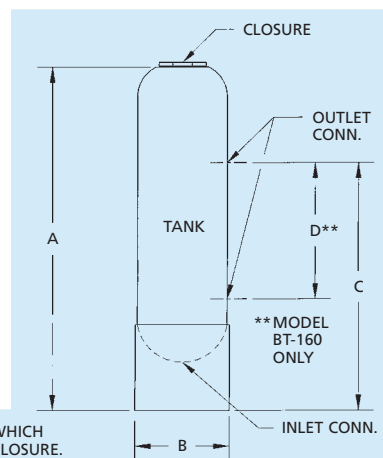

ALL MODELS EXCEPT BT-420 WHICH HAS OUTLET THROUGH TOP CLOSURE.

## PIPING KITS

PVC threaded fittings for operation to 120 psi at 100°F. Each Kit contains: two strainers, three ball valves, two tees, two 90° elbows, required nipples and plugs.

MODEL	DESCRIPTION	USE WITH
BP-75	3/4" NPT Piping Kit includes bushings to adapt 1/2" & 3/4" flow indicators.	BT-15, BT-40 & BT-42
BP-100	1" NPT Piping Kit includes bushings to adapt 3/4" & 1" flow indicators.	BT-80 & BT-160
BP-120	1" NPT Piping Kit includes bushings to adapt 3/4" & 1" flow indicators.	BT-420 only

## FLOW INDICATORS

5% accuracy, Polysulfone and CPVC with 316SS float. Male pipe connections. Rated to 150 psi at 120°F.

MODEL	RANGE (GPM)	CONN. (NPT)	USE WITH
FI-2	0.2- 2	1/2"	BT-15, BT-40, BT-42
FI-5	0.5- 5	1/2"	BT-15, BT-40, BT-42
FI-10	1- 10	3/4"	BT-42 through BT-420
FI-20	5- 21	1"	BT-160 or BT-420

## RELIEF VALVE

Specify RV-BR for 1/2" PVC safety relief valve. (Required for bromine service.)

## FUNNELS

Polyethylene funnels are available in two sizes to fit the 2-1/2" or 3-3/4" top opening of the bromine feeder body. A third funnel is offered which screws onto 5-gallon plastic pails with threaded tops.

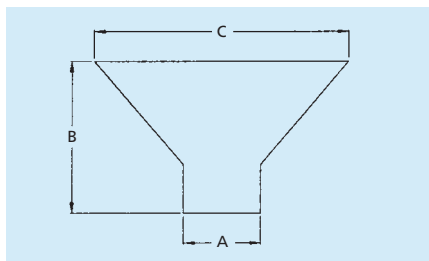

PART NUMBER	FITS MODELS	A	B	C
106894	BT-15, BT-40 only	2-3/8"	7-1/2"	9-1/2"
106807	All except BT-15, BT-40	3-1/2"	7"	11-1/2"
107898	*See note below	4-1/2"	6-1/2"	12-3/4"

\*Note:

Must be used in addition to one of the funnels above because outlet of this funnel is too large to fit tank opening.

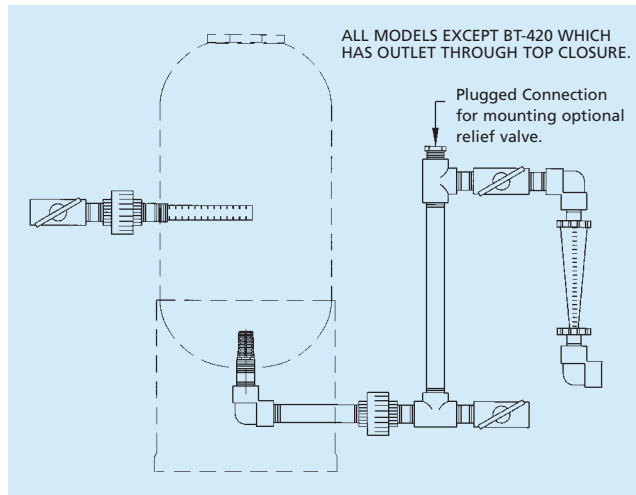

## DUAL SIZE CLOSURE WRENCH

Glass filled polypropylene wrench fits both 2-1/2" and 4" closures.

PART NUMBER 107282



SOLD BY:

P.O. Box 247 • Lansdale, PA 19446-0247  
 Tel: 215-699-8700 • Fax: 215-699-0370  
 Toll-Free Tel: 1-888-3NEPTUNE (1-888-363-7886)  
 Toll-Free Fax: 1-800-255-4017  
 Web Site: <http://www.neptune1.com>  
 E-mail: [pump@neptune1.com](mailto:pump@neptune1.com)